



The  
Electrical  
Power  
Engineers

## Qual-Tech Engineers, Inc.

201 Johnson Road – Building #1 · Suite 203  
Houston, PA 15342-1300

Phone 724-873-9275 – Fax 724-873-8910  
www.QualTechEng.com

# NEUTRAL GROUNDING REACTORS FOR GENERATORS

## Application...

### ▼ Reduce ground fault current

When generators of different designs are operated in parallel, the line-to-ground fault current can be significantly higher than the three phase fault current on the system and in the generators. Also, the line-to-ground fault current may be higher in a generator when it is operated in parallel with another generator than when it is operated as an isolated generator. This may result in excessive currents for circuit breakers and excessive forces in the generators during a single line-to-ground fault. The use of a neutral reactor or reactors can address this issue.

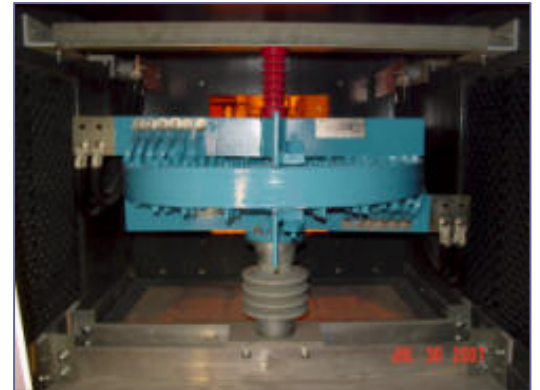

**Generator Neutral Reactor  
Figure 1**

### ▼ Reduce excessive generator third harmonic currents

Although generators are designed to produce power at a fundamental frequency, such as 25, 50, or 60 Hz, they can also produce small amounts of other frequencies. The highest of these other frequencies is often the third harmonic. As a result, in certain system configurations high third harmonic currents can occur. This high third harmonic current can result in overheating of the generators and the unexpected operation of ground fault relays.

The third harmonic is generally a zero sequence quantity. Consequently, this issue of high third harmonic currents occurs when there is more than one ground source on a system that has at least one local generator. A common configuration for this issue is illustrated in Figure 2. In this example, two three-phase generators are shown supplying power to a three-phase load. Each generator is connected in a wye-grounded configuration.

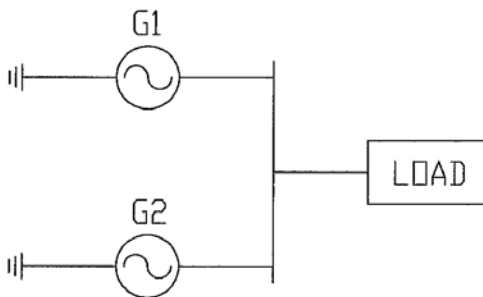

**High Third Harmonic Configuration**

**Figure 2**



**Enclosure for Generator Neutral Reactor  
Figure 3**

An equivalent circuit of the two generators at the third harmonic is illustrated in Figure 4. Each generator can produce some small amount of third harmonic voltage, generally in the range of 0.5% to 5%. The amount of third harmonic voltage is determined by the design of the generator, specifically the pitch of the generator windings. If identical generators are operated in parallel with identical load levels, there would be virtually no circulating current between them since the third harmonic voltages would be in phase with each other. If the loading on the generators is not identical, then the third harmonic voltages may not be identical and circulating third harmonic current can occur. The worst-case approach is to estimate the circulating third harmonic current based on having the maximum third harmonic voltage on the two generators with them being 180 degrees out of phase with each other. Based on the difference in the two voltages and the zero sequence impedances of the generators, a third

harmonic current will flow between the generators. These currents can be as high as 50% to 100% of the generator rated currents. Generally, limiting the third harmonic phase currents to < 5% of the generator ratings is acceptable. A relatively easy solution for the high third harmonic current is to insert a reactor in the neutral of one or both generators. (See Figure 5.)

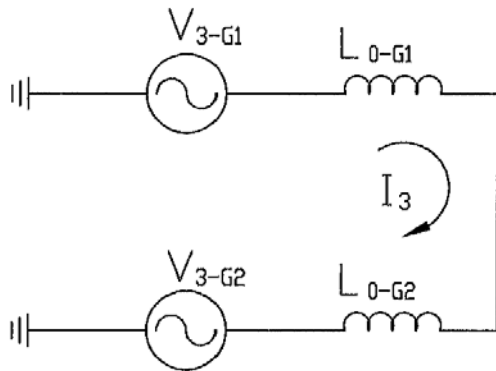

**Equivalent Circuit at the Third Harmonic  
Figure 4**

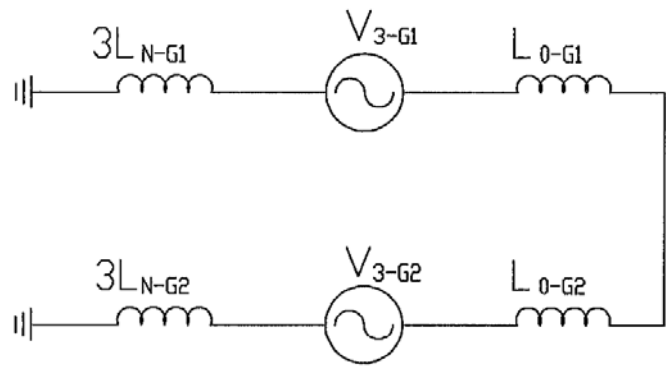

**Equivalent Circuit at the Third Harmonic  
With Neutral Reactor  
Figure 5**

Excessive third harmonic currents can occur for a number of different system configurations, such as when there are more than two generators operating in parallel or when there is a generator(s) operating in parallel with a wye-grounded transformer from a utility source.

**Qual-Tech Engineers** will design and supply properly engineered reactors to reduce the ground fault currents and third harmonic currents.